



Combinations in pictures may include optional accessories.

**HK 1042 Grapple Loader  
MV 106HD ATV Forest Trailer**

- Hydraulic extension
- Wide angle joint
- Strong N8 Grapple
- Fast mounting and removal
- Hydraulic aggregate integrated on the trailer's front screen device
- Hydraulic 4-wheel drive and hydraulic bogie transfer

***The profitable partner  
for year round loading  
and forwarding***

**High Quality Valve System**



**Technical data Nokka HK 1042**

Weight with timber grapple, kg	285
Gross lifting momentum, kNm	10
Net lifting momentum, kNm	7,6
Swing momentum, kNm (pressure 182 bar)	2,3
Boom turning angle	220°
Maximum reach, m	4,2
Slewing device	2 cylinders Flange, oil-bath/grease
Lifting capacity 2 m without grapple and rotator (- 60 kg)	400
Lifting capacity max. reach, kg without grapple and rotator (- 60 kg)	165
Weight without valve system, kg (Valve +37 kg)	630
Grapple, m²	0,08
Max. opening, cm	75

**Technical data Nokka MV 106HD ATV**

Weight without loader, kg	345
Load capacity speed 0-20 km/h, kg	1 000
speed 20-60 km/h, kg	290
Total weight, kg	1 630
Width, cm	n. 130
Length, cm	285-430
Height with grapple loader, cm	~185 cm
Length of load space, cm	187+100
Loading area, m²	0,65
Track width, cm	104
Ground clearance, cm	33
Motor, hp	5,4
Hydr. output, l/min	9
Max. working pressure	182 bar
Hydraulic oil tank, l	9,3
Tyres	22*11.00-8/4PR D-928

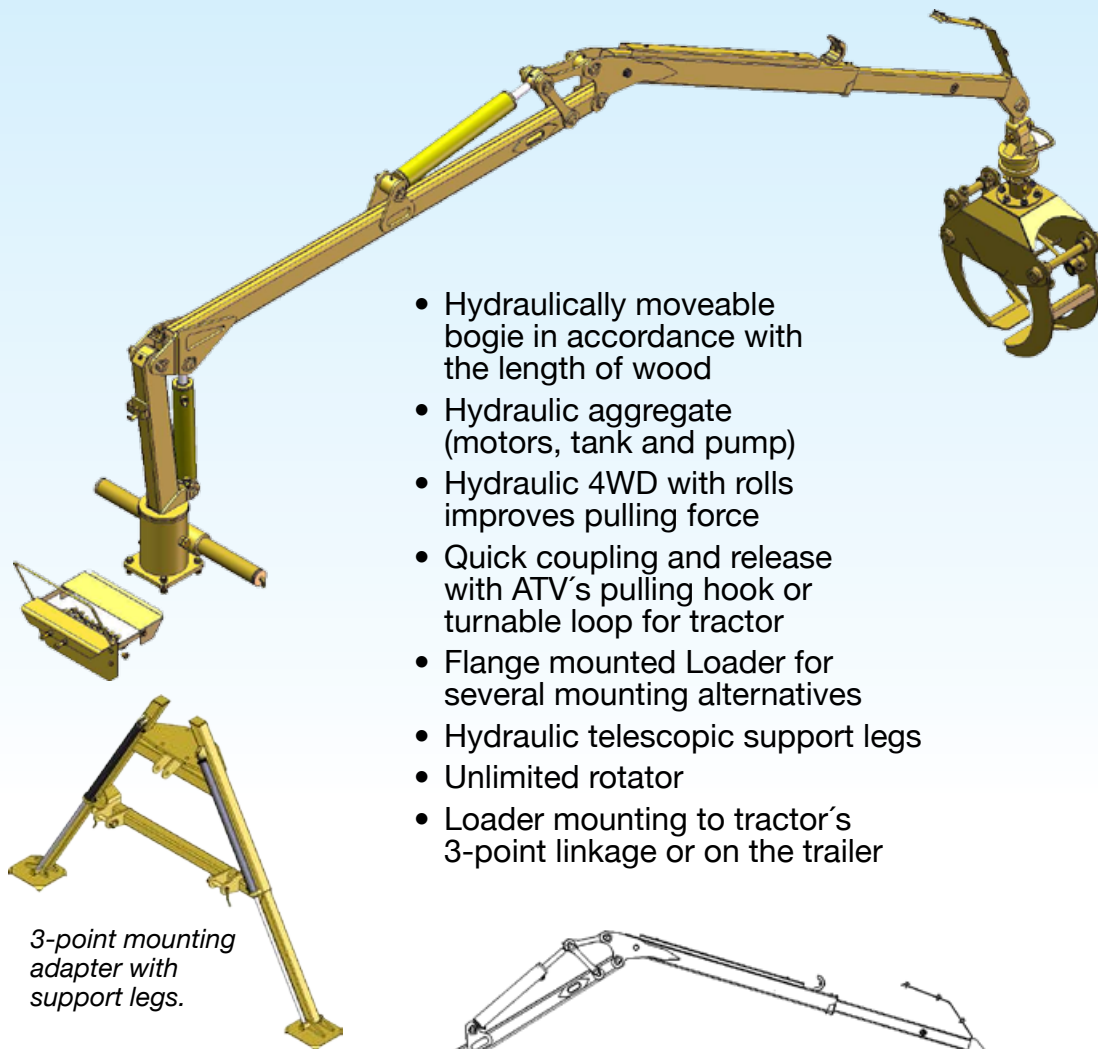

*3-point mounting adapter with support legs.*

- Hydraulically moveable bogie in accordance with the length of wood
- Hydraulic aggregate (motors, tank and pump)
- Hydraulic 4WD with rolls improves pulling force
- Quick coupling and release with ATV's pulling hook or turnable loop for tractor
- Flange mounted Loader for several mounting alternatives
- Hydraulic telescopic support legs
- Unlimited rotator
- Loader mounting to tractor's 3-point linkage or on the trailer

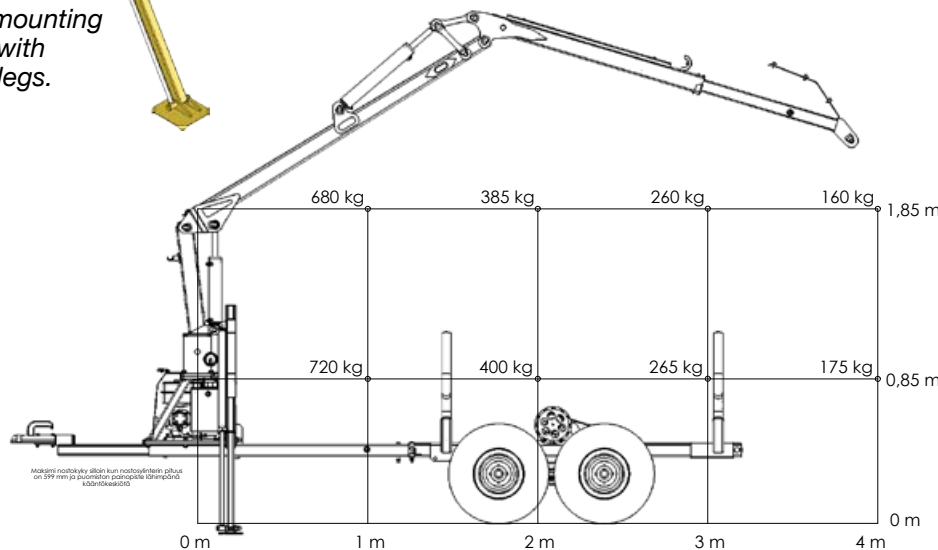

*Loader mounting on self-made trailer by mounting device module.*



*Hydraulic 4WD.*

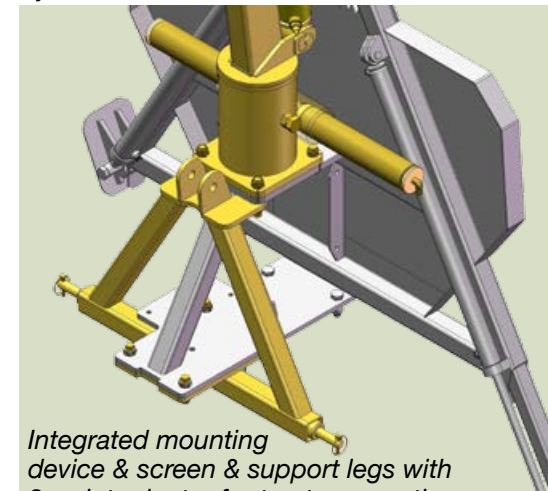

*Integrated mounting device & screen & support legs with 3-point adapter for tractor mounting.*

**Nokka Oy**

FI-40950 Muurame, Finland  
Tel. +358 44 76 24 505  
Fax +358 14 31 00 205  
nokka@nokka.fi  
www.nokka.fi

**IMPORTATEUR  
S.A. SCANTRAX  
Matériels forestiers**

Place Léopold Roger  
5660 Mariembourg, Belgique  
Bureau: +32 60 / 312501 ou 312194  
Fax: +32 60 / 312185  
info@scantrax.be  
www.scantrax.be